

ORDINANCE MC 62-22
AN ORDINANCE PROVIDING FOR THE ADOPTION OF THE 2021
INTERNATIONAL RESIDENTIAL BUILDING CODE AND AMENDMENTS AND
ADDITIONS THERETO; AND FOR THE REPEAL OF ALL ORDINANCES AND
RESOLUTIONS IN CONFLICT THEREWITH.

BE IT ORDAINED BY MINNEHAHA COUNTY, SOUTH DAKOTA:

SECTION 1. Adoption *International Residential Code 2021* edition.

The *International Residential Code*, 2021 edition including Appendix E, Appendix G, and Appendix H as published by the International Code Council Inc. as amended is hereby adopted as the residential building code by the county for regulating the design, construction, quality of materials, erection, installation, alteration, movement, repair, equipment, use and occupancy, location, removal, and demolition of detached one- and two-family dwellings and town houses not more than three stories in height with a separate means of egress and their accessory structures, and provides for the issuance of permits and the collection of fees therefore. The minimum building standards in the 2021 edition of the International Residential Code and amendments thereto shall be applied to any building permit issued after May 27th, 2022. The adoption of the International Residential Building Code, 2021 edition will become effective May 31st, 2022. A printed copy as amended is on file in the Auditor's Office.

SECTION 2. Repeal.

Ordinance MC55-19 is hereby repealed.

SECTION 3. AMENDMENTS, ADDITIONS, AND DELETIONS TO THE 2021 INTERNATIONAL RESIDENTIAL CODE.

The following sections and subsections of the 2021 International Residential Code adopted in this article shall be amended, added, or not adopted by the county as follows. All other sections or subsections of the 2021 International Residential Code as published shall remain the same.

R101.1 Title. These provisions shall be known as the *Residential Code for One- and Two-family Dwellings* of Minnehaha County, and shall be cited as such and will be referred to herein as "this code."

R101.2 Scope. The provisions of the *International Residential Code for One- and Two-family Dwellings* shall apply to the construction, *alteration*, movement, enlargement, replacement, repair, *equipment*, use and occupancy, location, removal and demolition of detached one- and two-family dwellings and *townhouses* not more than three stories above *grade plane* in height with a separate means of egress and their *accessory structures* not more than three stories above grade plane in height.

Exception 1: The following shall be permitted to be constructed in accordance with this code where provided with an automatic sprinkler system complying with Section P2904:

1. A care facility with five or fewer persons receiving custodial care within a dwelling unit.

2. A care facility with five or fewer persons receiving medical care within a dwelling unit.
3. A care facility for five or fewer persons receiving care that are within a single-family dwelling.

Exception 2: The following shall be permitted to be constructed in accordance with this code. A fire sprinkler system if installed may be in accordance with Section P2904.

1. Live/work units located in townhouses and complying with the requirements of Section 419 of the International Building Code.
2. Owner-occupied lodging houses with five or fewer guestrooms.

Exception 3: Existing buildings undergoing repair, alteration or additions and change of occupancies may be permitted to comply with the International Existing Building Code.

R102.4.3 Electrical. The term ICC Electrical Code shall mean the ICC Electrical Code as adopted by the State of South Dakota. ICC Electrical Code shall be administered by the State of South Dakota.

R102.4.4 Gas. The term International Fuel Gas Code shall mean the International Fuel Gas Code as adopted by the State of South Dakota. The International Fuel Gas Code shall be administered by the State of South Dakota.

R102.4.5 Mechanical. The term International Mechanical Code shall mean the International Mechanical Code as adopted by the State of South Dakota. The International Mechanical Code shall be administered by the State of South Dakota.

R102.4.6 Plumbing. The term ICC Plumbing Code shall mean the ICC Plumbing Code as adopted by the State of South Dakota. ICC Plumbing Code shall be administered by the State of South Dakota.

R102.4.7 Property maintenance. The term International Property Maintenance Code shall mean the International Property Maintenance Code as adopted by the State of South Dakota. The International Property Maintenance Code shall be administered by the State of South Dakota.

R102.4.8 Fire prevention. The term International Fire Code shall mean the International Fire Code as adopted by the State of South Dakota. The International Fire Code shall be administered by the State of South Dakota.

R102.4.9 Energy. The term International Energy Conservation Code shall mean the International Energy Conservation Code as adopted by the State of South Dakota. The International Energy Conservation Code shall be administered by the State of South Dakota.

R103.1 Enforcement agency. Minnehaha County Planning and Zoning is hereby created and the official in charge thereof shall be known as the building official.

R103.2 Appointment. Not adopted by Minnehaha County.

R104.8 Liability. The building official, member of the board of appeals or employee charged with the enforcement of this code, while acting for the jurisdiction in good faith and without malice in the discharge of the duties required by this code or other pertinent law or ordinance, shall not thereby be rendered civilly or criminally liable personally and is hereby relieved from personal liability for any damage accruing to persons or property as a result of any act or by reason of an act or omission in the discharge of official duties.

This code shall not be construed to relieve from or lessen the responsibility of any person owning, operating, or controlling any building or structure for any damages to persons or property caused by defects, nor shall the code enforcement agency or the county be held as assuming any such liability by reason of the inspection authorized by this code or any permits or certificates issued under this code.

R104.8.1 Legal defense. Any suit or criminal complaint instituted against an officer or employee because of an act performed by that officer or employee in the lawful discharge of duties and under the provisions of this code shall be afforded all the protection provided by the County's liability insurance and any immunities and defenses provided by other applicable state and federal law and defended by legal representatives of the *jurisdiction* until the final termination of the proceedings. The *building official* or any subordinate shall not be liable for cost in any action, suit or proceeding that is instituted in pursuance of the provisions of this code.

R105.1 Required. Any owner or owner's authorized agent who intends to construct, enlarge, alter, repair, move, demolish or change the occupancy of a building or structure, or to erect, install, enlarge, alter, repair, remove, convert or replace any electrical, gas, mechanical or plumbing system, the installation of which is regulated by this code, or to cause any such work to be performed, shall first make application to the *building official* and obtain the required *permit*. The building official may exempt permits for minor work.

R105.2 Work exempt from permit. Exemption from *permit* requirements of this code shall not be deemed to grant authorization for any work to be done in any manner in violation of the provisions of this code or any other laws or ordinances of this *jurisdiction*. Permits shall not be required for the following:

Building:

1. One-story detached *accessory structures*, provided that the floor area does not exceed 120 square feet (11 m²). Such structures must still meet applicable setback requirements of the 1990 Revised Zoning Ordinance for Minnehaha County, the 2001 Revised Joint Zoning Ordinance for Minnehaha County and the City of Dell Rapids, and the 2002 Revised Joint Zoning Ordinance for Minnehaha County and the City of Sioux Falls.

2. Fences not over 6 feet (1829 mm) high. Fences must still meet applicable requirements of the 1990 Revised Zoning Ordinance for Minnehaha County, the 2001 Revised Joint Zoning Ordinance for Minnehaha County and the City of Dell Rapids, and the 2002 Revised Joint Zoning Ordinance for Minnehaha County and the City of Sioux Falls.
3. Retaining walls that are not over 4 feet (1219 mm) in height measured from the bottom of the grade elevation to the top of the wall, unless supporting a surcharge.
4. Water tanks supported directly upon *grade* if the capacity does not exceed 5,000 gallons (18,927 L) and the ratio of height to diameter or width does not exceed 2 to 1.
5. Sidewalks and driveways. A driveway permit may be required by the applicable road authority.
6. Painting, papering, tiling, carpeting, cabinets, counter tops and similar finish work.
7. Prefabricated swimming pools that are less than 18 inches (457 mm) deep.
8. Swings and other playground equipment.
9. Window awnings supported by an exterior wall that do not project more than 54 inches (1,372 mm) from the exterior wall and do not require additional support.
10. Uncovered decks not exceeding 200 square feet (18.58 m²) in area, that are not more than 30 inches (762 mm) above *grade* at any point, are not attached to a dwelling and do not serve the exit door required by Section R311.4. Such structures must still meet applicable setback requirements of the 1990 Revised Zoning Ordinance for Minnehaha County, the 2001 Revised Joint Zoning Ordinance for Minnehaha County and the City of Dell Rapids, and the 2002 Revised Joint Zoning Ordinance for Minnehaha County and the City of Sioux Falls.

Electrical:

1. *Listed* cord-and-plug connected temporary decorative lighting.
2. Reinstallation of attachment plug receptacles but not the outlets therefor.
3. Replacement of branch circuit overcurrent devices of the required capacity in the same location.
4. Electrical wiring, devices, *appliances*, apparatus or *equipment* operating at less than 25 volts and not capable of supplying more than 50 watts of energy.
5. Minor repair work, including the replacement of lamps or the connection of *approved* portable electrical *equipment* to *approved* permanently installed receptacles.

Gas:

1. Portable heating, cooking or clothes drying *appliances*.
2. Replacement of any minor part that does not alter approval of *equipment* or make such *equipment* unsafe.
3. Portable-fuel-cell *appliances* that are not connected to a fixed piping system and are not interconnected to a power grid.

Mechanical:

1. Portable heating *appliances*.
2. Portable ventilation *appliances*.
3. Portable cooling units.
4. Steam, hot- or chilled-water piping within any heating or cooling *equipment* regulated by this code.
5. Replacement of any minor part that does not alter approval of *equipment* or make such *equipment* unsafe.
6. Portable evaporative coolers.
7. Self-contained refrigeration systems containing 10 pounds (4.54 kg) or less of refrigerant or that are actuated by motors of 1 horsepower (746 W) or less.
8. Portable-fuel-cell *appliances* that are not connected to a fixed piping system and are not interconnected to a power grid.

Plumbing:

1. The stopping of leaks in drains, water, soil, waste or vent pipe; provided, however, that if any concealed trap, drainpipe, water, soil, waste or vent pipe becomes defective and it becomes necessary to remove and replace the same with new material, such work shall be considered as new work and a *permit* shall be obtained and inspection made as provided in this code.
2. The clearing of stoppages or the repairing of leaks in pipes, valves or fixtures, and the removal and reinstallation of water closets, provided such repairs do not involve or require the replacement or rearrangement of valves, pipes or fixtures.

R105.5 Expiration. Every *permit* issued shall become invalid 365 days after its issuance. The *building official* is authorized to grant, in writing, one extension of time, for a period not more than 180 days. The extension shall be requested in writing and any fees paid before the original permit expires.

R106.1 Submittal documents. Submittal documents consisting of *construction documents*, and other data shall be submitted with each application for a *permit*. The *construction documents* shall be prepared by a registered *design professional* where required by the statutes of the *jurisdiction* in which the project is to be constructed. Where special conditions exist, the *building official* is authorized to require additional *construction documents* to be prepared by a registered *design professional*.

Exception: The *building official* is authorized to waive the submission of *construction documents* and other data not required to be prepared by a registered *design professional* if it is found that the nature of the work applied for is such that reviewing of *construction documents* is not necessary to obtain compliance with this code.

R106.1.6 Energy efficiency. Construction documents for detached one- and two-family dwellings and townhomes shall be provided with the intended R-value for the ceilings, walls, floors, basement walls (if finished), slab perimeter R-value and depth, and crawl space walls.

R106.1.7 Foundation reinforcement. Construction for detached one- and two-family dwellings and town houses shall be provided with the intended reinforcement of foundation walls referenced in Tables R404.1.1(2), R404.1.1(3), and R404.1.1(4) for reinforced masonry foundation walls; Tables R404.1.2(2), R404.1.2(3), R404.1.2(4), and R404.1.1(8) for flat concrete foundation walls; Tables 404.1.2(5) and R404.1.2(6) for waffle-grid basement walls; and Table R404.1.2(7) for screed-grid basement walls where the foundation wall exceeds the provisions for plain masonry and concrete foundation walls.

R106.3.1 Approval of construction documents. Where the *building official* issues a *permit*, the *construction documents* shall be submitted and reviewed One set of *construction documents* so reviewed shall be retained by the *building official*.

R108.2 Schedule of permit fees. On buildings, structures, electrical, gas, mechanical and plumbing systems or *alterations* requiring a *permit*, a fee for each *permit* shall be paid as required, in accordance with the schedule as established by Minnehaha County.

The fee schedules for the issuance of a building permit shall be as follows:

Table No. 1-A. Building Permit Fees

- | | |
|---|--|
| 1. Residential Structures _____ | \$60.00 or 0.4% of the construction costs, whichever is greater. |
| 2. Commercial/Industrial Structures _____ | \$100.00 or 1% of the construction costs, whichever is greater. |
| 3. Agricultural Structures _____ | \$30.00 or 0.2% of the construction costs, whichever is greater. |
| 4. Temporary Building Permit Fee _____ | \$60.00 |
| 5. Building Permit Extension _____ | \$50.00 (maximum 180 days) |

Table No. 1-B. Other Inspections and Fees

1. Inspections outside of normal business hours, per hour*
(minimum charge – one hour) _____ \$70.00
2. Inspections for which no fee is specifically indicated, per hour*
(minimum charge – one hour) _____ \$70.00
3. Change of Occupancy/Use Zoning Permit _____ \$50.00
4. Board of Appeals. Before the board takes any action, the party or parties requesting such hearing shall pay the fee of \$250.00. Under no condition shall said sum or any part thereof be refunded for failure of said request to be approved.
5. A mileage fee based on the current rate per mile authorized by the Internal Revenue Service shall be charged for any inspection occurring outside Minnehaha County.

R108.3 Building permit valuations. Building permit valuation shall include total value of the work for which a permit is being issued, such as electrical, gas, mechanical, plumbing equipment, and other permanent systems, including materials and labor. If, in the opinion of the building official, the valuation is underestimated on the application, the permit shall be denied, unless the applicant can show detailed estimates to meet the approval of the building official.

R108.6 Work commencing before permit issuance. Any person who commences any work on a building or structure before obtaining the necessary permits shall be subject to a fee equal to the required permit fee. The building official may apply said fee for each week the required permit is not obtained. Such fees are in addition to the required permit fees. Legal and/or civil proceedings may also be commenced.

R108.7 Delinquent accounts. The administrative authority may refuse to issue permits or conduct inspections for any person or business whose account is delinquent.

R109.1.1 Footing inspection. Inspection of the footing shall be made after poles or piers are set or trenches or *basement* areas are excavated and any required forms erected and any required reinforcing steel is in place and supported prior to the placing of concrete. The footing inspection shall include excavations for thickened slabs intended for the support of bearing walls, partitions, structural supports, or *equipment* and special requirements for wood foundations.

R109.1.2 Plumbing, mechanical, gas and electrical systems inspections. Shall be made by the State of South Dakota.

R109.1.3 Floodplain inspections. For construction in flood hazard areas as established by 2017 Floodplain Management Ordinance for Minnehaha County upon placement of the lowest floor, including *basement*, and prior to further vertical construction, the floodplain administrator shall require submission of documentation, prepared and sealed by a registered *design professional*, of the elevation of the lowest floor, including *basement*, required in 2017 Floodplain Management Ordinance for Minnehaha County.

R109.1.6.1 Elevation documentation. If located in a flood hazard area, the documentation of elevations required in Section R322.1.10 shall be submitted to the floodplain administrator prior to the final inspection.

R110.1 Use and change of occupancy. A building or structure shall not be used or occupied, and a change of occupancy or change of use of a building or structure or portion thereof shall not be made until the building official has completed a final inspection and all construction and code requirements have been met to the building official's satisfaction. Approval of a final inspection shall not be construed as an approval of a violation of the provisions of this code or of other ordinances of the county.

[A] 110.3 Certificate issued. After the *building official* inspects the building and does not find violations of the provisions of this code or other laws that are enforced by the Planning and Zoning Department, the *building official* may issue a certificate of occupancy containing the following:

1. The permit number.
2. The address of the structure.
3. A statement that the described portion of the structure has been inspected for compliance with the requirements of this code for the occupancy and division of occupancy and the use for which the proposed occupancy is classified.
4. The name of the *code official*.
5. The edition of the code under which the permit was issued.
6. If an automatic sprinkler system is provided and whether the sprinkler system is required.
7. Any special stipulations and conditions of the building permit.

R110.6 Placards. Placards or inspection record tags placed on the job by the inspectors to indicate approval of the work inspected shall not be removed, except when authorized by the building official.

R112.1 General. In order to hear and decide appeals of orders, decisions or determinations made by the building official or employee relative to the application and interpretation of this code, there shall be and is hereby created a Board of Appeals consisting of the members of the Minnehaha County Planning Commission. The Planning Commission acting as the board of appeals may call upon experts in the field of architecture, engineering and construction before making a decision on any appeal coming before them.

R112.2 Limitations on authority. An application for appeal shall be based on a claim that the true intent of this code or the rules legally adopted thereunder have been incorrectly interpreted,

the provisions of this code do not fully apply or an equally good or better form of construction is proposed. The board shall not have authority relative to the interpretation of the administrative provisions of this code nor shall the board be empowered to waive requirements of this code.

R113.3 Prosecution of violation. If the notice of violation is not complied with in the time prescribed by such notice, the *building official* is authorized to request the legal counsel of the *jurisdiction* to deem the violation as a strict liability offense and institute the appropriate proceeding at law or in equity to restrain, correct or abate such violation, or to require the removal or termination of the unlawful occupancy of the building or structure in violation of the provisions of this code or of the order or direction made pursuant thereto.

Section R202. Definitions. Add the following definition.

Strict liability offense. An offense in which the prosecution in a legal proceeding is not required to prove criminal intent as a part of its case. It is enough to prove that the defendant either did an act which was prohibited or failed to do an act which the defendant was legally required to do.

**TABLE R301.2
CLIMATIC AND GEOGRAPHIC DESIGN CRITERIA**

GROUND SNOW LOAD	WIND DESIGN				SEISMIC DESIGN CATEGORY ^f	SUBJECT TO DAMAGE FROM			ICE BARRIER UNDERLAYMENT REQUIRED ^h	FLOOD HAZARDS ^g	AIR FREEZING INDEX ⁱ	MEAN ANNUAL TEMP ^j
	Wind Speed ^d	Topographic Effects ^k	Special wind region ^l	Windborne Debris zone ^m		Weathering ^a	Frost line depth ^b	Termite ^c				
40psf	112	NO	NO	NO	A	Severe	42 Inches (1067 mm)	Slight to Moderate	Yes	<u>Minnehaha County entered the regular phase of the National Flood Insurance Program on September 5, 1979.</u>	3,000	46 degrees F

MANUAL J DESIGN CRITERIA^a

Elevation	Altitude correction factor	Coincident wet bulb	Indoor winter design dry-bulb temperature	Indoor winter design dry-bulb temperature	Outdoor winter design dry-bulb temperature	Heating temperature difference
1418	0.95	72 degrees F	70 degrees F	70 degrees F	-11 degrees F	81 degrees F
Latitude	Daily range	Indoor summer design relative humidity	Indoor summer design relative humidity	Indoor summer design dry-bulb temperature	Outdoor summer design dry-bulb temperature	Cooling temperature difference
43 degrees North	M	50% relative humidity	50% relative humidity	75 degrees F	90 degrees F	15 degrees F

For SI: 1 pound per square foot = 0.0479 kPa, 1 mile per hour = 0.447 m/s.

- a. Where weathering requires a higher strength concrete or grade of masonry than necessary to satisfy the structural requirements of this code, the frost line depth strength required for weathering shall govern. The weathering column shall be filled in with the weathering index, “negligible,” “moderate,” or “severe” for concrete as determined from Figure R301.2(1). The grade of masonry units shall be determined from ASTM C34, ASTM C55, ASTM C62, ASTM C73, ASTM C90, ASTM C129, ASTM C145, ASTM C216, or ASTM C652.

- b. Where the frost line depth requires deeper footings than indicated in Figure R403.1(1), the frost line depth strength required for weathering shall govern. The jurisdiction shall fill in the frost line depth column with the minimum depth of footing below finish grade.
- c. The jurisdiction shall fill in this part of the table to indicate the need for protection depending on whether there has been a history of local subterranean termite damage.
- d. The jurisdiction shall fill in this part of the table with the wind speed from the basic wind speed map [Figure R301.2(2)]. Wind exposure category shall be determined on a site-specific basis in accordance with Section R301.2.1.4.
- e. The jurisdiction shall fill in this section of the table to establish the design criteria using Table 10A from ACCA Manual J or established criteria determined by the jurisdiction.
- f. The jurisdiction shall fill in this part of the table with the seismic design category determined from Section R301.2.2.1.
- g. The jurisdiction shall fill in this part of the table with the date of the jurisdiction’s entry into the National Flood Insurance Program (date of adoption of the first code or ordinance for management of flood hazard areas); and the title and date of the currently effective Flood Insurance Study or other flood hazard study.
- h. In accordance with Sections R905.1.2, R905.4.3.1, R905.5.3.1, R905.6.3.1, R905.7.3.1, and R905.8.3.1, where there has been a history of local damage from the effects of ice damming, the jurisdiction shall fill in this part of the table with “YES.” Otherwise, the jurisdiction shall fill in this part of the table with “NO.”
- i. The jurisdiction shall fill in this part of the table with the 100-year return period air freezing index (BF-days) from Figure R403.3(2) or from the 100-year (99 percent) value on the National Climatic Data Center data table “Air Freezing Index-USA Method (Base 32°F).”
- j. The jurisdiction shall fill in this part of the table with the mean annual temperature from the National Climatic Data Center data table “Air Freezing Index-USA Method (Base 32°F).”
- k. In accordance with Section R301.2.1.5, where there is local historical data documenting structural damage to buildings due to topographic wind speed-up effects, the jurisdiction shall fill in this part of the table with “YES.” Otherwise, the jurisdiction shall indicate “NO” in this part of the table.
- l. In accordance with Figure R301.2(2), where there is local historical data documenting unusual wind conditions, the jurisdiction shall fill in this part of the table with “YES” and identify any specific requirements. Otherwise, the jurisdiction shall indicate “NO” in this part of the table.
- m. In accordance with Section R301.2.1.2 the jurisdiction shall indicate the wind-borne debris wind zone(s). Otherwise, the jurisdiction shall indicate “NO” in this part of the table.
- n. The jurisdiction shall fill in these sections of the table to establish the design criteria using Table 1a or 1b from ACCA Manual J or established criteria determined by the jurisdiction.
- o. The jurisdiction shall fill in this section of the table using the Ground Snow Loads in Figures R301.2(3) and R301.2(4).

TABLE R301.5
MINIMUM UNIFORMLY DISTRIBUTED LIVE LOADS
(in pounds per square foot)

USE	UNIFORM LOAD	CONCENTRATED LOAD
Uninhabitable attics without storage ^b	10	-
Uninhabitable attics with limited storage ^{b, g}	20	-
Habitable attics and attics served with fixed stairs	30	-
Balconies (exterior) and decks ^e	40	-
Fire escapes	40	-
Guards	-	200 ^{h, i}

Guardrails in-fill components ^f	-	50 ^h
Handrail ^d	200 ^h	-
Passenger vehicle garages ^a	50 ^a	2000 ^h
Rooms	40	-
	30	-
Stairs	40 ^c	300 ^c

For SI: 1 inch = 25.4 mm, 1 pound per square foot = 0.0479 kPa, 1 square inch = 645 mm², 1 pound = 4.45 N.

- a. Elevated garage floors shall be capable of supporting the uniformly distributed live load or a 2,000-pound concentrated load applied on an area of 4 1/2 inches by 4 1/2 inches, whichever produces the greater stresses.
- b. Uninhabitable attics without storage are those where the clear height between joists and rafters is not more than 42 inches, or where there are not two or more adjacent trusses with web configurations capable of accommodating an assumed rectangle 42 inches in height by 24 inches in width, or greater, within the plane of the trusses. This live load need not be assumed to act concurrently with any other live load requirements.
- c. Individual stair treads shall be capable of supporting the uniformly distributed live load or a 300-pound concentrated load applied on an area of 2 inches by 2 inches, whichever produces the greater stresses.
- d. A single concentrated load applied in any direction at any point along the top. For a guard not required to serve as a handrail, the load need not be applied to the top element of the guard in a direction parallel to such element.
- e. See Section R507.1 for decks attached to exterior walls.
- f. Guard in-fill components (all those except the handrail), balusters, and panel fillers shall be designed to withstand a horizontally applied normal load of 50 pounds on an area equal to 1 square foot. This load need not be assumed to act concurrently with any other live load requirement.
- g. Uninhabitable attics with limited storage are those where the clear height between joists and rafters is 42 inches or greater, or where there are two or more adjacent trusses with web configurations capable of accommodating an assumed rectangle 42 inches in height by 24 inches in width, or greater, within the plane of the trusses.

The live load need only be applied to those portions of the joists or truss bottom chords where all of the following conditions are met:

1. The attic area is accessed from an opening not less than 20 inches in width by 30 inches in length that is located where the clear height in the attic is not less than 30 inches.
 2. The slopes of the joists or truss bottom chords are no greater than 2 units vertical in 12 units horizontal.
 3. Required insulation depth is less than the joist or truss bottom chord member depth.
- The remaining portions of the joists or truss bottom chords shall be designed for a uniformly distributed concurrent live load of not less than 10 pounds per square foot.
- h. Glazing used in handrail assemblies and guards shall be designed with a load adjustment factor of 4. The load adjustment factor shall be applied to each of the concentrated loads applied to the top of the rail and to the load on the in-fill components. These loads shall be determined independent of one another, and loads are assumed not to occur with any other live load.
 - i. Where the top of a guard system is not required to serve as a handrail, the single concentrated load shall be applied at any point along the top in the vertical downward direction and in the horizontal direction away from the walking surface. Where the top of a guard is also serving as the handrail, a single concentrated load shall be applied in any direction at any point along the top. Concentrated loads shall not be applied concurrently.

**TABLE R302.1(1)
EXTERIOR WALLS**

EXTERIOR WALL ELEMENT		MINIMUM FIRE-RESISTANCE RATING	MINIMUM FIRE SEPARATION DISTANCE
Walls	Fire-resistance rated	1 hour—tested in accordance with ASTM E 119 or UL 263 with exposure from both sides	< 5 feet
	Not fire-resistance rated	0 hours	≥ 5 feet
Projections	Fire-resistance rated	1 hour on the underside	≥ 2 to < 3 feet
	Not fire-resistance rated	0 hours	≥ 3 feet
Openings	Not allowed	N/A	< 3 feet
	25% Maximum of Wall Area	0 hours	3 feet
	Unlimited	0 hours	5 feet
Penetrations	All	Comply with Section R317.3	< 5 feet
		None required	5 feet

For SI: 1 foot = 304.8 mm.

N/A = Not Applicable.

a. Roof eave fire-resistance rating shall be permitted to be reduced to 0 hours on the underside of the eave if fireblocking is provided from the wall top plate to the underside of the roof sheathing.

b. Roof eave fire-resistance rating shall be permitted to be reduced to 0 hours on the underside of the eave provided that gable vent openings are not installed.

R302.2.2 Common walls. Common walls separating *townhouse units* shall be assigned a fire-resistance rating in accordance with Item 1 or 2 and shall be rated for fire exposure from both sides. Common walls shall extend to and be tight against the exterior sheathing of the exterior walls, or the inside face of exterior walls without stud cavities, and the underside of the roof sheathing. The common wall shared by two *townhouse units* shall be constructed without mechanical equipment, ducts or vents, other than water-filled fire sprinkler piping in the cavity of the common wall. Electrical installations shall be in accordance with the National Electrical Code. Penetrations of the membrane of common walls for electrical outlet boxes shall be in accordance with Section R302.4. Plumbing installations shall be in accordance with the Uniform Plumbing Code. Membrane or tough penetrations of common walls for plumbing systems shall be in accordance with Section 302.4.

1. Where a fire sprinkler system in accordance with Section P2904 is provided, the common wall shall be not less than a 1-hour fire-resistance-rated wall assembly tested in accordance with ASTM E 119 or UL 263.

2. Where a fire sprinkler system in accordance with Section P2904 is not provided, the common wall shall be not less than a 2-hour fire-resistance-rated wall assembly tested in accordance with ASTM E 119 or UL 263.

R302.2.3 Continuity. The fire-resistance-rated wall or assembly separating *townhouses* shall be continuous from the foundation to the underside of the roof sheathing, deck or slab. The fire-resistance rating shall extend the full length of the wall or assembly, including wall extensions through and separating attached enclosed *accessory structures*.

Exterior walls that extend beyond an adjacent structure that has a fire separation distance less than 5 feet (1,523 mm) to a common property line shall have not less than a one-hour fire rating with exposure from both sides with no openings allowed therein.

Projections such as a deck that have a fire separation distance of less than 3 feet (914 mm) to a common property line shall have a 1-hour fire rating with exposure from both sides with no openings allowed therein that extends at least 30 inches (762 mm) above the projection.

R302.3 Two-family dwellings. Dwelling units in two-family dwellings shall be separated from each other by wall and floor assemblies having not less than a 1-hour fire-resistance rating where tested in accordance with ASTM E119, UL 263, or Section 703.2.2 of the International Building Code. Such separation shall be provided regardless of whether a lot line exists between the two dwelling units or not. Fire-resistance-rated floor/ceiling and wall assemblies shall extend to and be tight against the exterior wall, and wall assemblies shall extend from the foundation to the underside of the roof sheathing.

Exception: A fire-resistance rating of 1/2 hour shall be permitted in buildings equipped throughout with an automatic sprinkler system installed in accordance with Section P2904.

R302.13 Fire protection of floors. Not adopted by Minnehaha County.

R303.5.1 Intake openings. Mechanical and gravity outdoor air intake openings shall be located not less than 10 feet (3048 mm) from any hazardous or noxious contaminant, such as vents, chimneys, plumbing vents, streets, alleys, parking lots and loading docks.

For the purpose of this section, the exhaust from *dwelling* unit toilet rooms, bathrooms and kitchens shall not be considered as hazardous or noxious.

Exceptions: 1. The 10-foot (3048 mm) separation is not required where the intake opening is located 3 feet (914 mm) or greater below the contaminant source.

2. Vents and chimneys serving fuel-burning appliances shall be terminated in accordance with the applicable provisions of Chapters 18 and 24.

3. Clothes dryer exhaust ducts shall be terminated in accordance with Section M1502.3.

4. For equipment replacements on existing structures, gravity outdoor intake openings for combustion air shall be located a minimum of 3 feet (914 mm) from any hazardous or noxious contaminant.

R307.1 Space required. Fixtures shall be spaced in accordance with Figure R307.1.,.

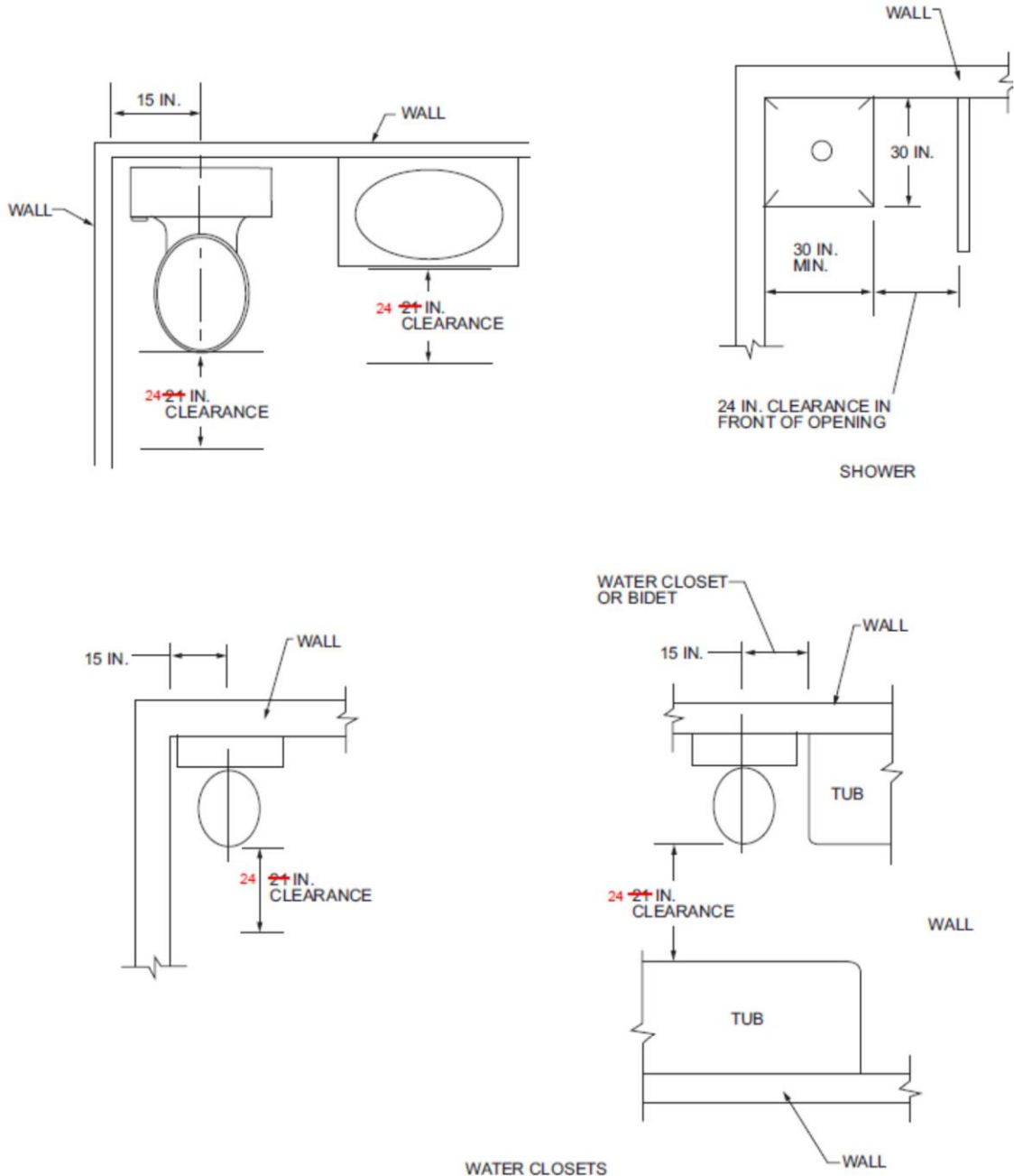

For SI: 1 inch = 25.4 mm.

FIGURE R307.1
MINIMUM FIXTURE CLEARANCES

R308.4.2 Glazing adjacent to doors. Glazing in an individual fixed or operable panel adjacent to a door shall be considered to be a hazardous location where the bottom exposed edge of the glazing is less than 60 inches (1524 mm) above the floor or walking surface and it meets either of the following conditions:

1. Where the glazing is within 24 inches (610 mm) of either side of the door in the plane of the door in a closed position.

2. Where the glazing is on a wall perpendicular to the plane of the door in a closed position and within 24 inches (610 mm) of the hinge side of an in-swinging door.

Exceptions:

1. Decorative glazing.
2. Where there is an intervening wall or other permanent barrier between the door and the glazing.
3. Where access through the door is to a closet or storage area 3 feet (914 mm) or less in depth. Glazing in this application shall comply with Section R308.4.3.
4. Glazing that is adjacent to the fixed panel of patio doors.

R309.5 Fire sprinklers. Not adopted by the Minnehaha County.

R310.2.1 Minimum size. Emergency and escape rescue openings shall have a net clear opening of not less than 5.0 square feet (0.465 m²).

R310.2.3 Maximum height from floor. Emergency escape and rescue openings shall have the bottom of the clear opening not greater than 48 inches (1,219 mm) above the floor.

R310.4.2 Ladder and steps. Area wells with a vertical depth greater than 48 inches (1,219 mm) shall be equipped with an approved, permanently affixed ladder or steps. The ladder or steps shall not be obstructed by the emergency escape and rescue opening where the window or door is in the open position. Ladders or steps required by this section shall not be required to comply with Section R311.7.

R310.4.2 Ladder and steps. Area wells with a vertical depth greater than 48 inches (1219 mm) shall be equipped with an approved, permanently affixed ladder or steps. The ladder or steps shall not be obstructed by the emergency escape and rescue opening where the window or door is in the open position. Ladders or steps required by this section shall not be required to comply with Section R311.7.

R311.3.1 Floor elevations at the required egress doors. Landings or finished floors at the required egress door shall be not more than 1 1/2 inches (38 mm) lower than the top of the threshold.

Exception: The landing or floor on the exterior side shall be not more than 8 inches (202 mm) below the top of the threshold provided the door does not swing over the landing or floor.

Where exterior landings or floors serving the required egress door are not at *grade*, they shall be provided with access to *grade* by means of a ramp in accordance with Section R311.8 or a stairway in accordance with Section R311.7.

R311.3.2 Floor elevations for other exterior doors. Doors other than the required egress door shall be provided with landings or floors not more than 8 inches (202 mm) below the top of the threshold.

Exception: A top landing is not required where a stairway of not more than two risers is located on the exterior side of the door, provided that the door does not swing over the stairway.

R311.7.5.1 Risers. The riser height shall be not more than 8 inches (202 mm). The riser height shall be measured vertically between leading edges of the adjacent treads. The greatest riser height within any flight of stairs shall not exceed the smallest by more than 3/8 inch (9.5 mm). Risers shall be vertical or sloped from the underside of the nosing of the tread above at an angle not more than 30 degrees (0.51 rad) from the vertical. Open risers are permitted.

Exceptions:

1. The opening between adjacent treads is not limited on spiral stairways.
2. The riser height of spiral stairways shall be in accordance with Section R311.7.10.1.

R311.7.8 Handrails. Handrails shall be provided on not less than one side of each flight of stairs with four or more risers.

Exception: When the landing at the top of the stair is not required to have a guardrail.

R311.7.8.4 Continuity. Handrails for stairways shall extend for the full length of the flight, from a point directly above the top riser of the flight to a point directly above the lowest riser of the flight. Handrail ends shall be returned to a wall, guard walking surface continuous to itself, or terminate to a post.

Exceptions:

1. Handrails shall be permitted to be interrupted by a newel post at a turn.
2. The use of a volute, turnout, starting easing, or starting newel shall be allowed over the lowest tread and over the top landing.

R311.7.8.5 Grip-size. Required handrails shall be of one of the following types or provide equivalent graspability.

1. Type I. Handrails with a circular cross section shall have an outside diameter of not less than 1 1/4 inches (32 mm) and not greater than 2 inches (51 mm). If the handrail is not circular, it shall have a perimeter dimension of not less than 4 inches (102 mm) and not greater than 6 1/4 inches (160 mm) with a cross section of dimension of not more than 2 1/4 inches (57 mm). Edges shall have a radius of not less than 0.01 inch (0.25 mm).
2. Type II. Handrails with a perimeter greater than 6 1/4 inches (160 mm) shall have a graspable finger recess area on both sides of the profile. The finger recess shall begin within a distance of 3/4 inch (19 mm) measured vertically from the tallest portion of the profile and achieve a depth of not less than 5/16 inch (8 mm) within 7/8 inch (22 mm) below the widest portion of the profile. This required depth shall continue for not

less than 3/8 inch (10 mm) to a level that is not less than 1 3/4 inches (45 mm) below the tallest portion of the profile. The width of the handrail above the recess shall be not less than 1 1/4 inches (32 mm) and not more than 23/4 inches (70 mm). Edges shall have a radius of not less than 0.01 inch (0.25 mm).

Exception: Exterior stairs are allowed to have a horizontal 2X member to form a 1 1/2-inch graspable dimension in lieu of the above-referenced perimeter dimensions.

R312.1.3 Opening limitations. Required *guards* shall not have openings from the walking surface to the required *guard* height that allow passage of a sphere 5 inches (127 mm) in diameter.

Exception:

The triangular openings at the open side of stair, formed by the riser, tread and bottom rail of a *guard*, shall not allow passage of a sphere 6 inches (153 mm) in diameter.

R312.2.1 Window opening height. In dwelling units, where the bottom of the clear opening of an operable window opening is located less than 24 inches (610 mm) above the finished floor and greater than 72 inches (1,829 mm) above the finished grade or other surface below on the exterior of the building, the operable window shall comply with one of the following:

1. Operable window openings will not allow a 5-inch-diameter (102 mm) sphere to pass through where the openings are in their largest opened position.
2. Operable windows are provided with window opening control devices or fall prevention devices that comply with ASTM F2090.

R313.1 Townhouse automatic fire sprinkler systems. Not adopted by the Minnehaha County.

R313.1.1 Design and installation. When automatic residential fire sprinkler systems for townhouses are installed, it shall be designed and installed in accordance with Section P2904 or NFPA 13D.

R313.2 One- and two-family dwellings automatic fire systems. Not adopted by the county.

R313.2.1 Design and installation. When automatic residential fire sprinkler systems are installed, it shall be designed and installed in accordance with Section P2904 or NFPA 13D.

R314.2.2 Alterations, repairs and additions. Where *alterations*, *repairs* or *additions* requiring a permit occur with a valuation of more than \$1000, or where one or more sleeping rooms are added or created in existing *dwellings*, the individual *dwelling unit* shall be equipped with smoke alarms located as required for new *dwellings*.

Exceptions:

1. Work involving the exterior surfaces of *dwelling*s, such as the replacement of roofing or siding, the *addition* or replacement of windows or doors, or the addition of a porch or deck, are exempt from the requirements of this section.

2. Installation, alteration or repairs of plumbing or mechanical systems.

R314.3 Location. Smoke alarms shall be installed in the following locations:

1. In each sleeping room.
2. Outside each separate sleeping area in the immediate vicinity of the bedrooms.
3. On each additional story of the dwelling, including basements and habitable attics and not including crawl spaces and uninhabitable attics. In dwellings or dwelling units with split levels and without an intervening door between the adjacent levels, a smoke alarm installed on the upper level shall suffice for the adjacent lower level provided that the lower level is less than one full story below the upper level. Smoke alarms shall be installed not less than 3 feet (914 mm) horizontally from the door or opening of a bathroom that contains a bathtub or shower unless this would prevent placement of a smoke alarm required by this section.
4. Not less than 3 feet (914 mm) horizontally from the door or opening of a bathroom that contains a bathtub or shower unless this would prevent placement of a smoke alarm required by this section.
5. In the hallway and in the room open to the hallway in dwelling units where the ceiling height of a room open to a hallway serving bedrooms exceeds that of the hallway by 24 inches (610mm) or more.

Exception. Hallways less than 4 feet (1,220 mm) in length are allowed to omit the smoke detector within the hallway adjacent to the bedrooms.

R314.4 Interconnection. Where more than one smoke alarm is required to be installed within an individual dwelling unit in accordance with Section R314.3, the alarm devices shall be interconnected in such a manner that the actuation of one alarm will activate all of the alarms in the individual dwelling unit. Physical interconnection of smoke alarms shall not be required where listed wireless alarms are installed and all alarms sound upon activation of one alarm.

Exception: Interconnection of smoke alarms in existing areas shall not be required where alterations or repairs do not result in removal of interior wall or ceiling finishes exposing the structure, unless there is an attic, crawl space or basement available that could provide access for interconnection without the removal of interior finishes.

R315.2.2 Alterations, repairs, and additions. Where *alterations*, repairs or *additions* requiring a permit occur with a valuation of more than \$1000, or where one or more sleeping rooms are

added or created in existing *dwellings*, the individual *dwelling unit* shall be equipped with carbon monoxide alarms located as required for new *dwellings*.

Exceptions:

1. Work involving the exterior surfaces of *dwellings*, such as the replacement of roofing or siding, or the addition or replacement of windows or doors, or the addition of a porch or deck.

2. Installation, alteration or repairs of plumbing or mechanical systems.

R319.1 Address numbers. This section not adopted by Minnehaha County.

R326.3 Story above grade plane. A habitable attic shall be considered a story above grade plane.

Exceptions: A habitable attic shall not be considered to be a story above grade plane provided that the habitable attic meets all the following:

1. The aggregate area of the habitable attic is either of the following:
 - 1.1 Not greater than one-third of the floor area of the story below.
 - 1.2 Not greater than one-half of the floor area of the story below where the habitable attic is located within a dwelling unit equipped with a fire sprinkler system in accordance with Section P2904.
2. The occupiable space is enclosed by the roof assembly above, knee walls, if applicable, on the sides and the floor-ceiling assembly below.
3. The floor of the habitable attic does not extend beyond the exterior walls of the story below.

R327.1 General. The design and construction of barriers for pools and spas shall comply with the following:

R327.2 Definitions. For the purposes of these requirements, the terms used shall be defined as follows and as set forth in Chapter 2.

ABOVEGROUND/ON-GROUND POOL. See “Swimming pool.”

BARRIER. A fence, wall, building wall or combination thereof that completely surrounds the swimming pool and obstructs access to the swimming pool.

HOT TUB. See “Swimming pool.”

IN-GROUND POOL. See “Swimming pool.”

RESIDENTIAL. That which is situated on the premises of a detached one- or two-family dwelling or a one-family *town house* not more than three stories in height.

SPA, NONPORTABLE. See “Swimming pool.”

SPA, PORTABLE. A nonpermanent structure intended for recreational bathing in which all controls, water-heating and water-circulating *equipment* are an integral part of the product.

SWIMMING POOL. Any structure intended for swimming or recreational bathing that contains water more than 18 inches (457 mm) deep. This includes in-ground, aboveground, and on-ground swimming pools, hot tubs, and spas.

SWIMMING POOL, INDOOR. A swimming pool that is totally contained within a structure and surrounded on all four sides by the walls of the enclosing structure.

SWIMMING POOL, OUTDOOR. Any swimming pool that is not an indoor pool.

R327.3 Application. The provisions of this appendix shall control the design of barriers for residential swimming pools, spas and hot tubs. These design controls are intended to provide protection against potential drownings and near-drownings by restricting access to swimming pools, spas and hot tubs.

This requirement shall be applicable to all new swimming pools hereafter constructed, other than indoor pools, and shall apply to all existing pools, which have a depth of 18 inches (457 mm) or more of water. No person in possession of land within the county, either as owner, purchaser, lessee, tenant, or a licensee, upon which is situated a swimming pool having a depth of 18 inches (457 mm) or more shall fail to provide and maintain such barrier as herein provided.

R327.4 Outdoor swimming pool. An outdoor swimming pool, including an in-ground, aboveground, or on-ground pool, hot tub or spa, shall be surrounded by a barrier that shall be installed, inspected, and approved prior to filling with water that completely surrounds and obstructs access to the swimming pool, which shall comply with the following:

1. The top of the barrier shall be at least 42 inches (1067mm) above *grade* measured on the side of the barrier that faces away from the swimming pool. The maximum vertical clearance between grade and the bottom of the barrier shall be 2 inches (51 mm) measured on the side of the barrier that faces away from the swimming pool. Where the top of the pool structure is above grade, such as an aboveground pool, the barrier may be at ground level, such as the pool structure, or mounted on top of the pool structure. Where the barrier is mounted on top of the pool structure, the maximum vertical clearance between the top of the pool structure and the bottom of the barrier shall be 4 inches (102 mm).
2. Openings in the barrier shall not allow the passage of a 4-inch-diameter (102 mm) sphere.

3. Where an aboveground pool structure is used as a barrier or where the barrier is mounted on top of the pool structure, and the means of access is a ladder or steps, then:
 - 3.1. The ladder or steps shall be capable of being secured or locked with a self-closing and self-latching device; or
 - 3.2. The ladder or steps shall be surrounded by a barrier, which meets the requirements of Item 1 above. When the ladder or steps are secured, locked, or removed, any opening created shall not allow the passage of a 4-inch-diameter (102 mm) sphere.
4. All gates or door openings through the barrier shall be equipped with self-closing and self-latching devices for keeping the door or gate securely closed at all times when the pool is not in actual use, except that the door of any dwelling that forms part of the enclosure need not be so equipped.

Exception: A property which meets all of the following standards and has an outdoor swimming pool shall be exempt from the requirements of Sections R326.4

1. The property is not within a residential zoning district.
2. The property is not located within a platted subdivision of five or more lots.
3. The swimming pool is greater than 500 feet from any dwelling other than a dwelling located on the same property.

R327.4.1 Barrier exceptions. Spas or hot tubs with a safety cover that comply with ASTM F 1346 shall be exempt from the provisions of this appendix. Modifications in individual cases, upon a showing of good cause with respect to height, nature, or location of a fence, wall, gates, or latches, or the necessity thereof, may be made by the building official, provided the protection as sought hereunder is not reduced thereby. The building official may grant permission for other protective devices or structures to be used as long as the degree of protection afforded by this substitute device or structure is not less than the protection afforded by the wall, fence, gate, and latch described herein. A reasonable period within which to comply with the requirements of this section for existing swimming pools shall be allowed, which period shall not exceed 90 days after notification by the building official.

R403.1.4.1 Frost protection. Except where otherwise protected from frost, foundation walls, piers, and other permanent supports of buildings and structures shall be protected from frost by one or more of the following methods:

1. Extended below the frost line specified in Table R301.2.
2. Constructed in accordance with Section R403.3.
3. Constructed in accordance with ASCE 32.

4. Erected on solid rock.

Exceptions: 1. Protection of freestanding *accessory structures* with an area of 1500 square feet (139 m²) or less, of light-frame construction, with an eave height of 10 feet (3048 mm) or less shall not be required.

2. Protection of freestanding *accessory structures* with an area of 400 square feet (37 m²) or less, of other than light-frame construction, with an eave height of 10 feet (3048 mm) or less shall not be required.

3. Decks not supported by a dwelling need not be provided with footings that extend below the frost line.

Footings shall not bear on frozen soil unless the frozen condition is permanent.

R502.3.1 Sleeping areas and attic joists. Table R502.3.1(1) shall be used to determine the maximum allowable span of floor joists that support sleeping areas and *attics* that are accessed by means of a fixed stairway in accordance with Section R311.7 provided that the design live load does not exceed 40 pounds per square foot (1.92 kPa) and the design dead load does not exceed 20 pounds per square foot (0.96 kPa). The allowable span of ceiling joists that support *attics* used for limited storage or no storage shall be determined in accordance with Section R802.4.

R506.2.3 Vapor retarder. A minimum 6-mil (0.006 inch; 0.152 mm) vapor retarder conforming to ASTM E1745 Class A requirements with joints lapped not less than 6 inches (152 mm) shall be placed between the concrete floor slab and the base course or the prepared subgrade where a base course does not exist.

Exception: The vapor retarder is not required for the following:

1. Garages, utility buildings, and other unheated accessory structures.
2. For unheated storage rooms having an area of less than 70 square feet (6.5 m²) and carports.
3. Driveways, walks, patios, and other flatwork not likely to be enclosed and heated at a later date.
4. Where approved by the building official, based on local site conditions.

R507.3 Footings. Decks shall be supported on concrete footings or other approved structural systems designed to accommodate all loads in accordance with Section R301. Deck footings shall be sized to carry the imposed loads from the deck structure to the ground as shown in Figure R507.3.

Exception: Decks not supported by a dwelling need not be provided with footings that extend below the frost line.

R602.10.1.2 Location of braced wall lines and permitted offsets. Each *braced wall line* shall be located such that no more than two-thirds of the required *braced wall panel* length is located to one side of the *braced wall line*. Braced wall panels shall be permitted to be offset up to 4 feet (1,219 mm) from the designated *braced wall line*. Braced wall panels parallel to a *braced wall line* shall be offset not more than 4 feet (1,219 mm) from the designated *braced wall line* location as shown in Figure R602.10.1.1.

Exterior walls parallel to a braced wall line shall be offset not more than 4 feet (1,219 mm) from the designated braced wall line location as shown in Figure R602.10.1.1.

Interior walls used as bracing shall be offset not more than 4 feet (1,219 mm) from a braced wall line through the interior of the building as shown in Figure R602.10.1.1.

Exception: The offset out-of-plane may exceed 4 feet (1219 mm) and the out-to-out offset dimension may exceed 8 feet (2438 mm) if the area of the offset is less than 200 square feet (18.6 m²).

R602.12 Simplified wall bracing. Buildings meeting all of the conditions listed below shall be permitted to be braced in accordance with this section as an alternate to the requirements of Section R602.10. The entire building shall be braced in accordance with this section; the use of other bracing provisions of Section R602.10, except as specified herein, shall not be permitted.

1. There shall be not more than three stories above the top of a concrete or masonry foundation or basement wall. Permanent wood foundations shall not be permitted.
2. Floors shall not cantilever more than 24 inches (607 mm) beyond the foundation or bearing wall below.
3. Wall height shall not be greater than 12 feet (3,658 mm).
4. The building shall have a roof eave-to-ridge height of 20 feet (6096 mm) or less.
5. Exterior walls shall have gypsum board with a minimum thickness of 1/2 inch (12.7 mm) installed on the interior side fastened in accordance with Table R702.3.5.
6. The structure shall be located where the ultimate design wind speed is less than or equal to 130 mph (58 m/s), and the exposure category is B or C.
7. The structure shall be located in Seismic Design Category A, B or C for detached one- and two-family dwellings or Seismic Design Category A or B for townhouses.
8. Cripple walls shall not be permitted in three-story buildings.

R806.2 Minimum vent area. The minimum net free ventilating area shall be 1/150 of the area of the vented space.

Exception: The minimum net free ventilation area shall be 1/300 of the vented space provided one or more of the following conditions are met:

1. In Climate Zones 6, 7 and 8, a Class I or II vapor retarder is installed on the warm-in winter side of the ceiling.
2. Not less than 40 percent and not more than 50 percent of the required ventilating area is provided by ventilators located in the upper portion of the attic or rafter space. Upper ventilators shall be located not more than 3 feet (914 mm) below the ridge or highest point of the space, measured vertically. The balance of the required ventilation provided shall be located in the bottom one-third of the attic space. Where the location of wall or roof framing members conflicts with the installation of upper ventilators, installation more than 3 feet (914 mm) below the ridge or highest point of the space shall be permitted.

N1101.2 (R101.3) Intent. This chapter shall regulate the design and construction of buildings for the effective use and conservation of energy over the useful life of each *building*. Additions, alterations, renovations, or repairs to an existing building, building system or portion thereof may conform to the provisions of this code as they relate to new construction without requiring the unaltered portion(s) of the existing building or building system to comply with this code. This chapter is intended to provide flexibility to permit the use of innovative approaches and techniques to achieve this objective. This chapter is not intended to abridge safety, health or environmental requirements contained in other applicable codes or ordinances.

Table N1102.1.3 (R402.1.3)										
Insulation Minimum R-Values and Fenestration Requirements by Component^a										
Climate Zone	Fenestration U-Factor ^{b,i}	Skylight ^b U-Factor	Glazed Fenestration SHGC ^{b, e}	Ceiling R-Value ^k	Wood Frame Wall R-Value ^g	Mass Wall R-Value ^h	Floor R-Value	Basement ^{c,9} Wall R-Value	Slab ^d R-Value & Depth	Crawl Space ^{c,9} Wall R-Value
6	0.32	0.55	NR	49	20 or 13 + 5 ^h	15/19	30 ^j	10/13	10ci, 4 ft	10/13
For SI: 1 foot = 304.8 mm										
NR = Not Required.										
a. R-values are minimums. U-factors and SHGC are maximums. Where insulation is installed in a cavity which is less than the label or design thickness of the insulation, the installed R-value of the insulation shall not be less than the R-value specified in the table.										
b. The fenestration U-factor column excludes skylights. The SHGC column applies to all glazed fenestration. <i>Exception:</i> In Climate Zones 0 through 3, skylights shall be permitted to be excluded from glazed fenestration SHGC requirements provided that SHGC for such skylights does not exceed 0.30.										
c. "5ci or 13" means R-5 continuous insulation (ci) on the interior or exterior surface of the wall or R-13 cavity insulation on the interior side of the wall. "10ci or 13" means R-10 continuous insulation (ci) on the interior or exterior surface of the wall or R-13 cavity insulation on the interior side of the wall. "15ci or 19 or 13 + 5ci" means R-15 continuous insulation (ci) on the interior or exterior surface of the wall; or R-19 cavity insulation on the interior side of the wall; or R-13 cavity insulation on the interior of the wall in addition to R-5 continuous insulation on the interior or exterior surface of the wall. "10/13" means R-10 continuous insulation										

on the interior or exterior of the home or R-13 cavity insulation on the interior of the basement wall. “15/19” means R-15 continuous insulation on the interior or exterior of the home or R-19 cavity insulation on the interior of the basement wall. Alternatively, compliance with “15/19” shall be R-13 cavity insulation on the interior of the basement wall plus R-5 continuous insulation on the interior or exterior of the home.
d. R-5 insulation shall be provided under the full slab area of a heated slab in addition to the required slab edge insulation R-value for slabs, as indicated in the table. The slab edge insulation for heated slabs shall not be required to extend below the slab.
e. There are no SHGC requirements in the Marine Zone.
f. Basement wall insulation is not required in warm humid locations as defined by Figure N1101.7 and Table N1101.7.
g. The first value is cavity insulation; the second value is continuous insulation. Therefore, as an example, “13 + 5” means R-13 cavity insulation plus R-5 continuous insulation.
h. Mass walls shall be in accordance with Section N1102.2.5. The second R-value applies where more than half of the insulation is on the interior of the mass wall.
i. A maximum U-factor of 0.32 shall apply in Climate Zones 3 through 8 to vertical fenestration products installed in buildings located either: <ol style="list-style-type: none"> 1. Above 4,000 feet in elevation; or 2. In windborne debris regions where protection of openings is required by Section R301.2.1.2.
j. Alternatively, insulation sufficient to fill the framing cavity providing not less than an R-value of R-19.
k. The minimum R-value for ceilings is further based on a minimum 6-inch (152 mm) heel height to allow the ceiling insulation to extend over the top plate.

For SI: 1 foot = 304.8 mm.

- a. R-values are minimums. U-factors and SHGC are maximums. When insulation is installed in a cavity which is less than the label or design thickness of the insulation, the installed R-value of the insulation shall not be less than the R-value specified in the table.
- b. The fenestration U-factor column excludes skylights. The SHGC column applies to all glazed fenestration.
 - Exception:** Skylights may be excluded from glazed fenestration SHGC requirements in Climate Zones 1 through 3 where the SHGC for such skylights does not exceed 0.30.
- c. “15/19” means R-15 continuous insulation on the interior or exterior of the home or R-19 cavity insulation at the interior of the basement wall. “15/19” shall be permitted to be met with R-13 cavity insulation on the interior of the basement wall plus R-5 continuous insulation on the interior or exterior of the home. “10/13” means R-10 continuous insulation on the interior or exterior of the home or R-13 cavity insulation at the interior of the basement wall. The perimeter wall of an enclosed mechanical room is allowed to not be a component of the thermal envelope.
- d. R-5 shall be added to the required slab edge R-values for heated slabs. Insulation depth shall be the depth of the footing or 2 feet, whichever is less in Zones 1 through 3 for heated slabs.
- e. There are no SHGC requirements in the Marine Zone.
- f. Basement wall insulation is not required in warm-humid locations as defined by Figure N1101.10 and Table N1101.10.
- g. Or insulation sufficient to fill the framing cavity, R-19 minimum.
- h. The first value is cavity insulation, the second value is continuous insulation, so “13+5” means R-13 cavity insulation plus R-5 continuous insulation.
- i. The second R-value applies when more than half the insulation is on the interior of the mass wall.
- j. The minimum R-value for ceilings is further based on a minimum 6-inch (152 mm) heel height to allow the ceiling insulation to extend over the top plate.

N1102.2.8.1 (R402.2.8.1) Basement wall insulation installation. Where basement walls are insulated, the insulation shall be installed from the top of the basement wall down to 10 feet (3,048 mm) below grade or to the basement floor, whichever is less.

Exception: Exterior basement walls of enclosed mechanical rooms.

N1102.4.1.2 (R402.4.1.2) Testing. Not adopted by the Minnehaha County.

N1102.4.1.3 (R402.4.1.3) Leakage rate. Not adopted by Minnehaha County.

N1102.4.4 (R402.4.4) Rooms containing fuel-burning appliances. Not adopted by Minnehaha County.

N1102.4.6 (R402.4.6) Electrical and communication outlet boxes (air-sealed boxes). Not adopted by Minnehaha County.

N1103.3.1 (R403.3.1) Ducts located outside conditioned space. Supply and return ducts located outside conditioned space shall be insulated to an R-value of not less than R-8 for ducts 3 inches (76 mm) in diameter and larger and not less than R-6 for ducts smaller than 3 inches (76 mm) in diameter.

N1103.3.5 (R403.3.5) Duct testing. Not adopted by the Minnehaha County.

N1103.5 (R403.5) Service hot water systems. Energy conservation measures for service hot water systems shall be in accordance with the Uniform Plumbing Code.

N1103.6.3 (R403.6.3) Testing. Not adopted by Minnehaha County.

N1104.1 (R404.1) Lighting equipment (Mandatory). Not adopted by Minnehaha County.

N1109.2 (R501.2) Compliance. *Additions, alterations, repairs* or changes of occupancy to, or relocation of, an existing *building, building* system or portion thereof may comply with Section N1110, N1111, N1112 or N1113, respectively, in this code. Changes where unconditioned space is changed to *conditioned space* shall comply with Section N1110.

N1110.1 (R502.1) General. *Additions* to an existing *building, building* system or portion thereof may conform to the provisions of this chapter as they relate to new construction without requiring the unaltered portion of the existing *building* or *building* system to comply with this chapter. *Additions* shall not create an unsafe or hazardous condition or overload existing *building* systems. An *addition* shall be deemed to comply with this chapter where the *addition* alone complies, where the existing *building* and *addition* comply with this chapter as a single *building*, or where the *building* with the *addition* does not use more energy than the existing *building*. *Additions* shall be in accordance with Section N1110.2 or N1110.3.

N1111.1 (R503.1) General. *Alterations* to any *building* or structure may comply with the requirements of the code for new construction, without requiring the unaltered portions of the existing *building* or *building* system to comply with this chapter. *Alterations* shall be such that the existing *building* or structure is not less conforming with the provisions of this chapter than the existing *building* or structure was prior to the *alteration*.

Alterations shall not create an unsafe or hazardous condition or overload existing *building* systems. *Alterations* shall be such that the existing *building* or structure does not use more energy than the existing *building* or structure prior to the *alteration*. *Alterations* to existing *buildings* shall comply with Sections N1111.1.1 through N1111.1.4.

N1112.1 (R504.1) *Buildings*, structures and parts thereof may be repaired in compliance with Section N1109.3 and this section. Work on nondamaged components necessary for the required repair of damaged components shall be considered to be part of the *repair* and shall not be subject to the requirements for *alterations* in this chapter. Routine maintenance required by Section N1109.3, ordinary *repairs* exempt from *permit*, and abatement of wear due to normal service conditions shall not be subject to the requirements for *repairs* in this section.

N1113.1 (R505.1) General. Any space that is converted to a *dwelling unit* or portion thereof from another use or occupancy may comply with this chapter.

Exception: Where the simulated performance option in Section N1105 is used to comply with this section, the annual energy cost of the *proposed design* is permitted to be 110 percent of the annual energy cost allowed by Section N1105.2.

M1305.1.3.1 Ground clearance. *Equipment* and *appliances* supported from the ground shall be level and firmly supported on a concrete slab or other *approved* material extending not less than 1 ½ inches (38 mm) above the adjoining ground. Such support shall be in accordance with the manufacturer’s installation instructions. *Appliances* suspended from the floor shall have a clearance of not less than 6 inches (152 mm) from the ground.

M1305.1.3.3 Electrical requirements. A luminaire controlled by a switch located at the required passageway opening and a receptacle outlet shall be installed at or near the appliance location in accordance with National Electric Code. Exposed lamps shall be protected from damage by location or lamp guards.

M1502.4.2 Duct installation. Exhaust ducts shall be supported at 4-foot (1219 mm) intervals and shall be secured in place. The insert end of the duct shall extend into the adjoining duct or fitting in the direction of airflow. Exhaust duct joints shall be sealed in accordance with Section M1601.4.1. Ducts shall not be joined with screws or similar fasteners that protrude into the inside of the duct. Where dryer exhaust ducts are enclosed in wall or ceiling cavities, such cavities shall allow the installation of the duct without deformation.

M1504.2 Duct length. The length of exhaust and supply ducts used with ventilating equipment shall not exceed the lengths determined in accordance with Table M1506.2 as revised.

**TABLE M1504.2
DUCT LENGTH**

Fan Airflow Rating (CFM)	0-80	81-125	126-200	201-300	Over 300
Minimum duct diameter (inches)	4	5	6	7	8

M1504.3 Exhaust openings. Air exhaust openings shall terminate as follows:

1. Not less than 3 feet (914 mm) from property lines.
2. Not less than 3 feet (914 mm) from gravity air intake openings, operable windows and doors. 3
3. Not less than 10 feet (3048 mm) from mechanical air intake openings except where the exhaust opening is located not less than 3 feet (914 mm) above the air intake opening. Openings shall comply with Sections R303.5.2 and R303.6.
4. Minimum clearance between the exhaust and intake openings of an HRV/PRV system shall be in accordance with the manufacturer's installation instructions.

M1505.4 Whole-house mechanical ventilation system. Whole-house mechanical ventilation systems shall be designed in accordance with Sections M1505.4.1 through M1505.4.4.

Exceptions:

1. A bathroom exhaust fan shall operate continuously at a minimum rate of 20 cfm. A 6-inch-round passive makeup air shall be provided. If opening directly into the occupied space, such opening shall not decrease the comfort conditions of the occupied space. Such opening may also be used to provide combustion air for fuel-fired appliances if sized and designed for combustion air purposes. If opening into the mechanical room, permanent openings shall be provided between the mechanical room and occupied space to provide a path of travel for the air. The exhaust fan shall be located in the bathroom farthest away from the source of makeup air and shall be rated for 0.8 sones or less.
2. A 4-inch-round outdoor air duct connected to the return side of the air handler. The duct shall be insulated to a minimum R-6 and shall connect to the return duct within 8 feet of the air handler connection, not above a finished ceiling.

**TABLE M1505.4.4
MINIMUM REQUIRED LOCAL EXHAUST RATES FOR ONE- AND TWO-FAMILY DWELLINGS**

AREA TO BE EXHAUSTED	EXHAUST RATES
Bathrooms - Toilet Rooms	Mechanical exhaust capacity of 50 cfm intermittent or 20 cfm continuous

Section M1506 Subslab Soil Exhaust Systems.

M1506.1 General. When a subslab soil exhaust system is provided, the duct shall conform to the requirements of this section.

M1506.2 Materials. Subslab soil exhaust system duct material shall be air duct material listed and labeled to the requirements of UL 181 for Class 0 air ducts, or any of the following piping

materials that comply with the *Plumbing Code* as building sanitary drainage and vent pipe: cast iron; galvanized steel; brass or copper pipe; copper tube of a weight not less than that of copper drainage tube, Type DWV; and plastic piping.

M1506.3 Grade. Exhaust system ducts shall not be trapped and shall have a minimum slope of 1/8 unit vertical in 12 units horizontal (1 percent slope).

M1506.4 Termination. Subslab soil exhaust system ducts shall extend through the roof and terminate at least 6 inches (152 mm) above the roof and at least 10 feet (3,048 mm) from any operable openings or air intake.

M1601.1.1 Above-ground duct systems. Above-ground *duct systems* shall conform to the following:

1. *Equipment* connected to *duct systems* shall be designed to limit discharge air temperature to not greater than 250°F (121°C)
2. Factory-made ducts shall be listed and labeled in accordance with UL 181 and installed in accordance with the manufacturer's instructions. Flexible air ducts shall be limited in length to 14 feet. Flexible air connectors are not allowed.
3. Fibrous glass duct construction shall conform to the SMACNA *Fibrous Glass Duct Construction Standards* or NAIMA *Fibrous Glass Duct Construction Standards*.
4. Field-fabricated and shop-fabricated metal and flexible duct constructions shall conform to the SMACNA HVAC Duct Construction Standards—Metal and Flexible except as allowed by Table M1601.1.1. Galvanized steel shall conform to ASTM A 653, except that sheet steel and strip used for duct, connectors, and round duct shall be G40 galvanized steel of lock-forming quality.
5. The use of gypsum products to construct return air ducts or plenums is permitted, provided that the air temperature does not exceed 125°F (52°C) and exposed surfaces are not subject to condensation.
6. *Duct systems* shall be constructed of materials having a flame spread index of not greater than 200.
7. Stud wall cavities and the spaces between solid floor joists to be used as air plenums shall comply with the following conditions:
 - 7.1. These cavities or spaces shall not be used as a plenum for supply air.
 - 7.2. These cavities or spaces shall not be part of a required fire-resistance-rated assembly.

7.3. Stud wall cavities shall not convey air from more than one floor level.

7.4. Stud wall cavities and joist-space plenums shall be isolated from adjacent concealed spaces by tight-fitting fire blocking in accordance with Section R302.11. Fire blocking materials used for isolation shall comply with Section R302.11.1.

7.5. Stud wall cavities in the outside walls of the building envelope assemblies shall not be utilized as air plenums.

8. Volume dampers, equipment and other means of supply, return and exhaust air adjustment used in system balancing shall be provided with access.

M1601.1.2 Underground duct systems. Underground duct systems shall be constructed of approved concrete, clay, metal or plastic. The maximum design temperature for systems utilizing plastic duct and fittings shall be 150°F (66°C). Metal ducts shall be protected from corrosion in an approved manner or shall be completely encased in concrete not less than 2 inches (51 mm) thick. Nonmetallic ducts shall be installed in accordance with the manufacturer's instructions. Plastic pipe and fitting materials shall conform to cell classification 12454-B of ASTM D1248 or ASTM D1784 and external loading properties of ASTM D2412. Ducts shall slope to a drainage point that has access. Ducts shall be sealed, secured, and tested prior to encasing the ducts in concrete or direct burial. Metallic ducts having an approved protective coating and nonmetallic ducts shall be installed in accordance with the manufacturer's instructions.

M1601.4.1 Joints, seams and connections. Longitudinal and transverse joints, seams and connections in metallic and nonmetallic ducts shall be constructed as specified in *SMACNA HVAC Duct Construction Standards—Metal and Flexible* and *NAIMA Fibrous Glass Duct Construction Standards*. Joints, longitudinal and transverse seams, and connections in ductwork outside the building thermal envelope; all return ducts located within 10 feet (3.05 m) of any appliance or all return ducts within a mechanical room; and all supply main trunk ducts and branch duct connections to the main trunk ducts shall be securely fastened and sealed with welds, gaskets, mastics (adhesives), mastic-plus-embedded-fabric systems, liquid sealants or tapes. Tapes and mastics used to seal fibrous glass ductwork shall be *listed* and *labeled* in accordance with UL 181A and shall be marked "181A-P" for pressure-sensitive tape, "181 A-M" for mastic or "181 A-H" for heat-sensitive tape.

Tapes and mastics used to seal metallic and flexible air ducts and flexible air connectors shall comply with UL 181B and shall be marked "181 B-FX" for pressure-sensitive tape or "181 BM" for mastic. Duct connections to flanges of air distribution system equipment shall be sealed and mechanically fastened. Mechanical fasteners for use with flexible nonmetallic air ducts shall comply with UL 181B and shall be marked 181B-C. Crimp joints for round metallic ducts shall have a contact lap of not less than 1 inch (25 mm) and shall be mechanically fastened by means of not less than three sheet-metal screws or rivets equally spaced around the joint.

Closure systems used to seal all ductwork shall be installed in accordance with the manufacturers' instructions.

Exceptions:

1. Spray polyurethane foam shall be permitted to be applied without additional joint seals.
2. Where a duct connection is made that is partially inaccessible, three screws or rivets shall be equally spaced on the exposed portion of the joint so as to prevent a hinge effect.
3. For ducts having a static pressure classification of less than 2 inches of water column (500 Pa), additional closure systems shall not be required for continuously welded joints and seams and locking-type joints and seams of other than the snap-lock and button-lock types.

M1601.4.4 Support. Factory-made ducts listed in accordance with UL 181 shall be supported in accordance with the manufacturer's installation instructions. Field- and shop-fabricated fibrous glass ducts shall be supported in accordance with the SMACNA *Fibrous Glass Duct Construction Standards* or the NAIMA *Fibrous Glass Duct Construction Standards*. Field- and shop-fabricated metal and flexible ducts shall be supported in accordance with the SMACNA *HVAC Duct Construction Standards—Metal and Flexible*. Metal ducts shall be supported by 1/2-inch-wide (13 mm) 18-gage, 1-inch-wide (25 mm) 24-gage, or 1 1/2-inch-wide (39 mm) 26-gage metal straps or 12-gage galvanized wire at intervals not exceeding 10 feet (3048 mm) or other *approved* means.

G2402.3 (201.3) Terms defined in other codes. Where terms are not defined in this code and are defined in the *International Building Code*, *International Fire Code*, NFPA-70, *International Mechanical Code*, *International Fuel Gas Code*, or *Uniform Plumbing Code*, such terms shall have meanings ascribed to them as in those codes.

G2407.6 (304.6) Outdoor combustion air. Outdoor *combustion* air shall be provided through opening(s) to the outdoors in accordance with Section G2407.6.1, G2407.6.2, or G2407.6.3. The minimum dimension of air openings shall be not less than 3 inches (76 mm).

Combustion air intake opening shall be located a minimum of 3 feet (914 mm) from a gas meter.

G2407.6.3 Alternate combustion air sizing. As an alternate the net free area of openings, ducts, or plenums supplying air to an area containing gas- and oil-burning appliances shall be in accordance with B149.1-10, Natural Gas and Propane Installation Code, published by the Canadian Standards Association (CSA).

The combustion air duct is required to be upsized one diameter size when a dryer is installed in the same room as the combustion air.

G2408.1 (305.1) General. *Equipment* and *appliances* shall be installed as required by the terms of their approval, in accordance with the conditions of listing, the manufacturer's instructions and this code. Manufacturer's installation instructions shall be available on the job site at the

time of inspection. Where a code provision is less restrictive than the conditions of the listing of the *equipment* or *appliance* or the manufacturer's installation instructions, the conditions of the listing and the manufacturer's installation instructions shall apply.

After completion of the installation, all safety and operating controls and venting shall be tested before placing the burner in service in accordance with the manufacturer's installation instructions. The following requirements need to be recorded and affixed to the inside of the gas train access panel:

1. The rate of flow of the gas or fuel shall be adjusted to within plus or minus 5 percent of the required Btu/hr rating at the manifold pressure specified by the manufacturer. When the prevailing pressure is less than the manifold pressure specified, the rates shall be adjusted at the prevailing pressure.
2. The gas inlet pressure per the manufacturer's installation settings.
3. The temperature rise across the heat exchanger per the manufacturer's installation settings.
4. The static pressure of the supply and return ducts per the manufacturer's installation settings.

Unlisted *appliances approved* in accordance with Section G2404.3 shall be limited to uses recommended by the manufacturer and shall be installed in accordance with the manufacturer's instructions, the provisions of this code and the requirements determined by the *code official*.

G2408.4 (305.7) Equipment and appliances installed at grade level shall be supported on a level concrete slab or other approved material extending not less than 1½ inches (38 mm) above adjoining grade or shall be suspended not less than 6 inches (152 mm) above adjoining grade. Such supports shall be installed in accordance with the manufacturer's instructions.

G2410.2 (309.2) Connections. Electrical connections between appliances and the building wiring, including the grounding of the appliances, shall conform to Chapters 34 through 43 the National Electric Code.

G2415.2 (404.2) CSST. CSST piping systems shall be installed in accordance with the terms of their approval, the conditions of listing, the manufacturer's instructions and this code.

The piping located on the exterior extending from the gas meter to the inside of the structure shall be a metallic pipe in compliance with Section G2414.4. The entrance into the structure shall be provided with the appropriate transition flange where an alternate gas piping material is utilized on the inside of the structure.

G2415.3 (404.3) Prohibited locations. *Piping* shall not be installed in or through a ducted supply, return or exhaust, or a clothes chute, *chimney* or gas vent, dumbwaiter or elevator shaft.

G2415.6 (404.6) Piping through foundation walls. Underground piping, where installed through the outer foundation or basement wall of a building shall be encased in a protective sleeve or protected by an approved device or method. The space between the gas piping and the sleeve and between the sleeve and the wall shall be sealed to prevent the entry of gas and water.

G2415.12 (404.12) Minimum burial depth. Underground piping systems shall be installed a minimum depth of 12 inches (305 mm) below grade, The minimum depth shall be increased to 18 inches (457 mm) if external damage to the piping or tubing from external forces is likely to result. Where a minimum of 12 inches (305 mm) of depth cannot be provided, the pipe shall be installed in conduit or bridged (shielded).

G2415.12.1(404.12.1) Individual outdoor appliances. Not adopted by Minnehaha County.

G2420.1.2 (409.1.2) Prohibited locations. Shutoff valves shall be prohibited in concealed locations, furnace plenums, and accessible spaces between a fixed ceiling and a dropped ceiling unless serving a gas appliance installed in that space.

Part VII—Plumbing. The following chapters are not adopted by Minnehaha County: Chapter 25—Plumbing Administration; Chapter 26—General Plumbing Requirements; Chapter 27—Plumbing Fixtures; Chapter 28—Water Heaters; Chapter 29—Water Supply and Distribution, except Section P2904 Dwelling Unit Fire Sprinkler System; Chapter 30—Sanitary Drainage; Chapter 31—Vents; Chapter 32—Traps; and Chapter 33—Storm Drainage.

The provisions of the most current plumbing code adopted by the South Dakota State Plumbing Commission shall apply to the installation, alterations, repairs, and replacement of plumbing systems, including equipment, appliances, fixtures, and appurtenances, and where connected to a water or sewage system for detached one- and two-family dwellings and multiple single-family dwellings (town houses) not more than three stories high with separate means of egress and their accessory structures.

Part VIII—Electrical. The following chapters are not adopted by the Minnehaha County: Chapter 34—General Requirements; Chapter 35—Electrical Definitions; Chapter 36—Services; Chapter 37—Branch Circuit and Feeder Requirements; Chapter 38—Wiring Methods; Chapter 39—Power and Lighting Distribution; Chapter 40—Device and Luminaires; Chapter 41—Appliance Installation; Chapter 42—Swimming Pools; Chapter 43—Class 2 Remote-Control, Signaling and Power-Limited Circuits.

The provisions of the National Electrical Code as adopted by the South Dakota State Electrical Commission shall apply to the installation, alteration, repair, relocation, replacement, addition to, use, or maintenance of any electrical system, apparatus, wiring, or equipment for electrical, light, heat, power, fire alarms, and associate controls for detached one- and two-family dwellings and multiple single-family dwellings (town houses) not more than three stories high with separate means of egress and their accessory structures.

Adopted this 19th day of April, 2022.

MINNEHAHA COUNTY

Chair, Board of County Commissioners

ATTEST:

County Auditor

1 st Reading	March 22, 2022
Legal Ad Argus Leader, Brandon Valley Journal, Garretson Gazette, Minnehaha Messenger	March 28, 2022 March 30, 2022 March 31, 2022 April 1, 2022
Public Hearing	April 19, 2022
Fact of Adoption Argus Leader, Brandon Valley Journal, Garretson Gazette, Minnehaha Messenger	April 25 & May 2, 2022 April 27 & May 4, 2022 April 28 & May 5, 2022 April 29 & May 6, 2022
Effective Date	May 31, 2022